

# Accu Control Box for 1 or 2 Lifting Columns or Actuators

# MCB-LCB2

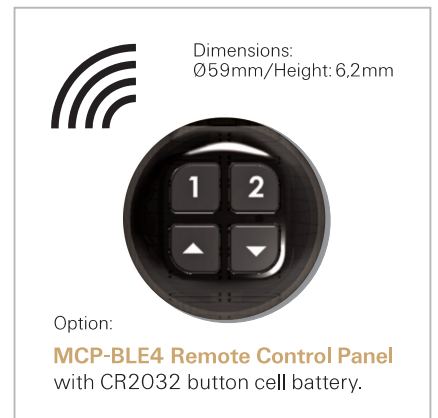
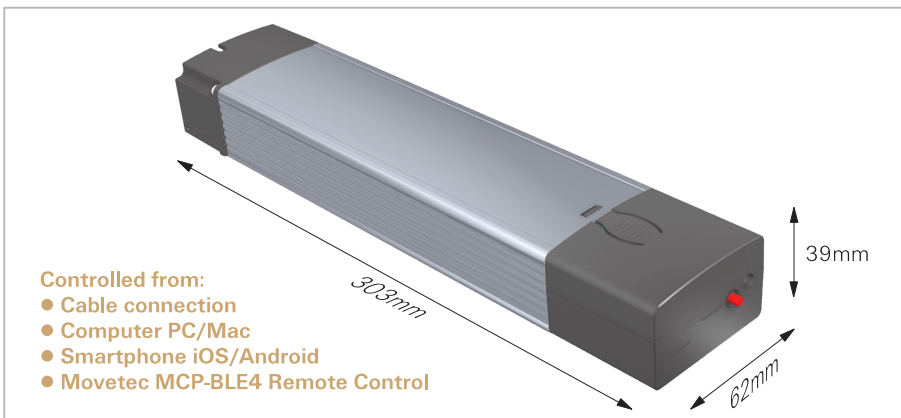
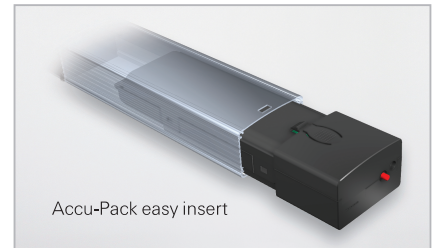
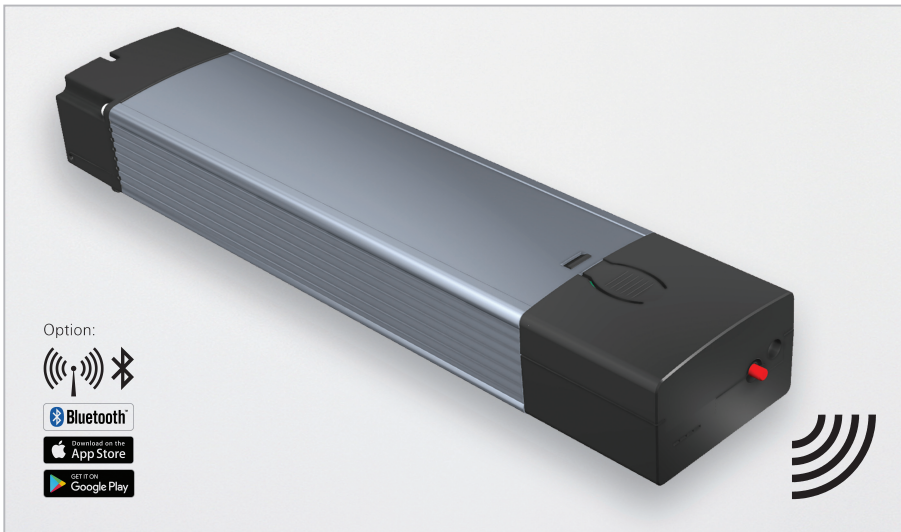

## Accu Control Box MCB-LCB2

Controlled via remote control, Smartphone, PC/Mac or cable connection. For 1 or 2 lifting columns or actuators.

In the MCB-LCB series, the power supply is replaced by an 86 Wh accu pack. MCB-LCB2 is slightly longer than the MCB-LC2. The mounting points are identical for all series. MCB-LCB2 is mounted, connected and configured in the same way as MCB-LC2 with power supply. The accu pack is inserted at the end where the mains plug is plugged in for the MCB-LC2. The capacity of the accu pack is generously dimensioned, as a rule operation over several months is possible. The accu pack can be changed easily. The accu pack can be charged inside or outside the controller. The external charging option ensures that there is always a charged battery pack in the controller. 4 LED's on the battery pack indicate the current state of charge. Charging via a plug-in power supply unit. MCB-LCB2 is a control box specially designed for use with height-adjustable worktables/workspaces - controlled via remote control, Smartphone, PC/Mac or cable connection. It is also suitable and configured for all types of industrial and medical applications. The bus system supports easy configuration. You can synchronise up to 4 control boxes.

**Plug & Play:** MCB-LCB2 is a Plug & Play control box, supplied with all required cables. It can be supplied as part of a complete set, with your choice of remote control, tailor-made lifting columns/actuators, extra accus.

## Technical data:

Control box capacity, number of lifting columns/actuators: 1 or 2  
 Applications: Suitable for all Movetec lifting columns and actuators  
 Cascade/synchronous operation: Yes, up to 8 lifting columns/actuators  
 Synchronisation: Via modus  
 Bluetooth®: Radio standard BLE4.0 (option)  
 Accu Pack capacity: 86Wh  
 Input voltage, charger: 115 to 230V 50/60Hz  
 Output voltage: 24 V, max. output: 300 W  
 Output current: 15 A, max. current per channel: 12 A  
 Plugs and sockets for lifting columns and actuators: Molex 8-pole  
 Plugs and sockets for control panel devices: RJ12  
 Continuous operation up to: 100 W total load  
 Hall sensor compatible: Yes  
 Standby power consumption: 250 mW  
 Dimensions (LxW xH): 303mm (Accu Pack incl.) x 62mm x 38.5 mm  
 Memory positions: Yes, depending on the control panel device  
 Collision protection/anti-collision system, low-speed zone: Yes (option)  
 Operating temperature range: +5° to +45° C  
 IP protection class: IP20. Class I, output insulated low voltage  
 Optional safety zone, sensor connection, config./end-stop contact: Yes  
**Option:** Additional functions (e.g. records position, go-to-position, etc., depending on control panel device version), Bluetooth®.



# Accu Control Box for 1 or 2 Lifting Columns or Actuators

# MCB-LCB2

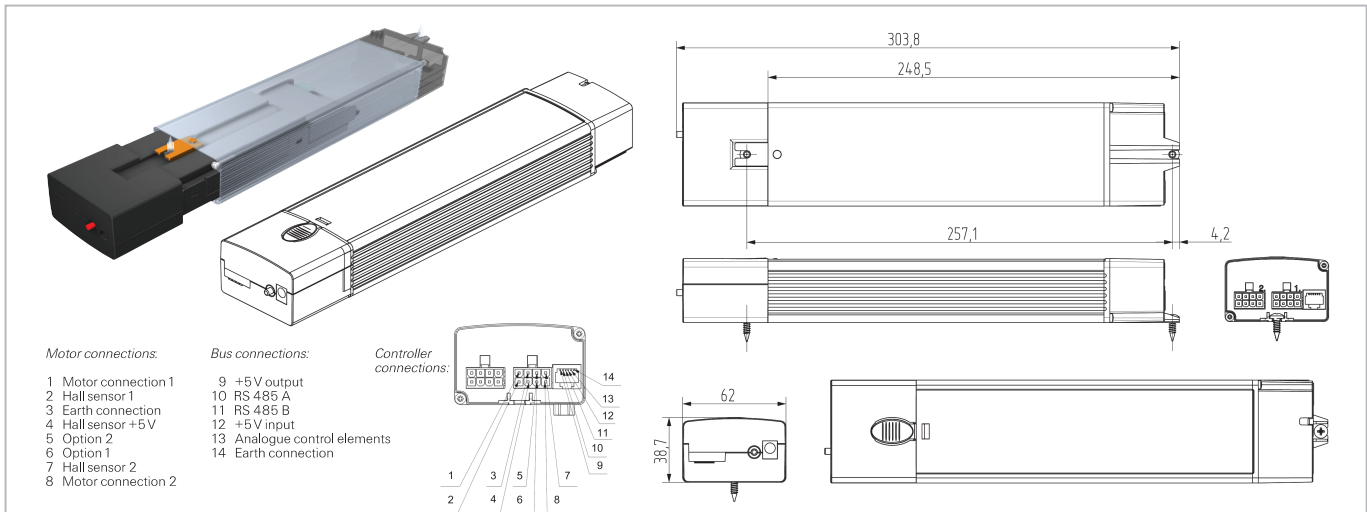

**Motor connections:**

- 1 Motor connection 1
- 2 Hall sensor 1
- 3 Earth connection
- 4 Hall sensor +5V
- 5 Option 2
- 6 Option 1
- 7 Hall sensor 2
- 8 Motor connection 2

**Bus connections:**

- 9 +5V output
- 10 RS 485 A
- 11 RS 485 B
- 12 +5V input
- 13 Analogue control elements
- 14 Earth connection

**Controller connections:**

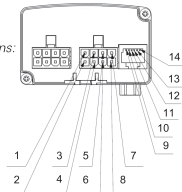

Option: MCP-BLE4 remote control panel.  
Radio standard: Bluetooth® BLE 4.0, range: about 100 m (in an open environment)

**Specifications:**

Casing, plugs, sockets, cable: Aluminium, PC, ABS, PVC, PP, PE.

**Optimal versatility:** Movetec control boxes can be adapted to comply with precise customer requirements. If coordinated movements are required, we develop customised software for the application. The software may also include integration with a primary control system. Movetec control boxes are designed for use in e.g. furniture, ergonomic workspaces, medical or industrial applications.

**Scalable software:** Movetec offers high quality lifting columns and linear actuator systems. The control box functions as the system's brain and is therefore a key system element. Our highly motivated team of software engineers develops bespoke control box software and ensures a perfect match with system components. A tailor-made software design also offers more complex system functions, including synchronisation and simultaneous movement.

**Individual, synchronised and simultaneous movements:** Hall sensors transmit feedback signals to the control box. These signals give the precise current position of the electric lifting column or linear actuator. The signals can be used to provide synchronised and simultaneous movement on demand of two or more electric lifting columns or linear actuators. Applications that require synchronised movements include height-adjustable desks, hospital beds and innumerable industrial applications. Synchronised operation ensures that the lifting columns or actuators remain at the same level and move at the same speed. Without synchronisation, the lifting columns or actuators would move at different rates/levels.

**RJ12 and Molex plugs and sockets:**

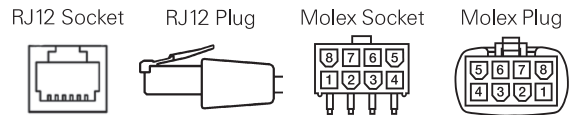

MCB-LCB2 connections: RJ 12 sockets for all control panel devices and connection to the primary control box. Molex sockets for all lifting columns and actuators.

**Control panels, lifting columns and actuators:**

MCB-LCB2 can be used with various Movetec control panel devices and all Movetec lifting columns and actuators. An MCB-LCB2 control box can be programmed to operate in customer-specific applications and functions. Together, we can develop a solution that matches specific customer requirements and wishes: Call us on +45 64 89 28 05.

**CAD drawings:**

You can download 3D drawings (STEP data) for MCB-LCB2 either for use with CAD software or as PDF files from our website.

**Manuals, installation instructions, authorisations, safety information, etc.:**

Declaration of compliance, fitting and installation instructions, warnings, video guidelines and other information material are available from our website: [www.movetec.dk](http://www.movetec.dk).



Bluetooth® is a registered trademark and are the property of the owner Bluetooth SIG, Inc. Android®/ Google Play® is registered trademarks and are the property of the owner Google Inc. Apple®/ App Store® is registered trademarks and are the property of the owner Apple Inc. Other trademarks and trade names are the property of their respective owners.

Further information → [www.movetec.dk](http://www.movetec.dk)



Tel. +45 64 89 28 05 · [www.movetec.dk](http://www.movetec.dk)



True Innovative Moving Technology